

PLAN VIEW

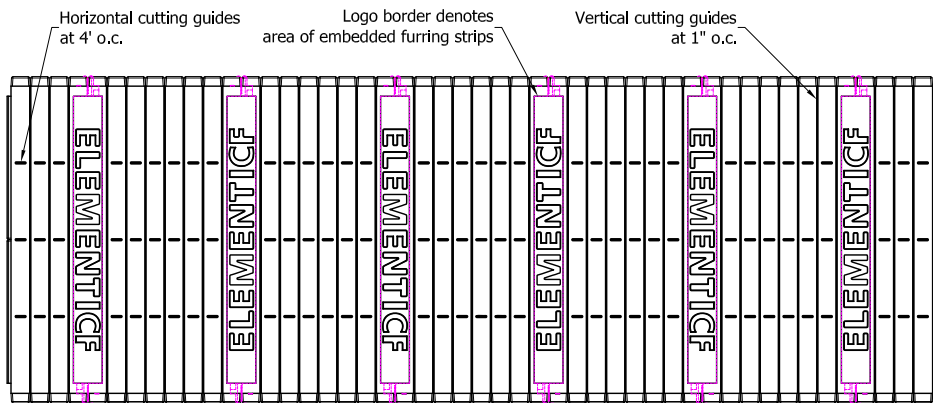

SIDE ELEVATION

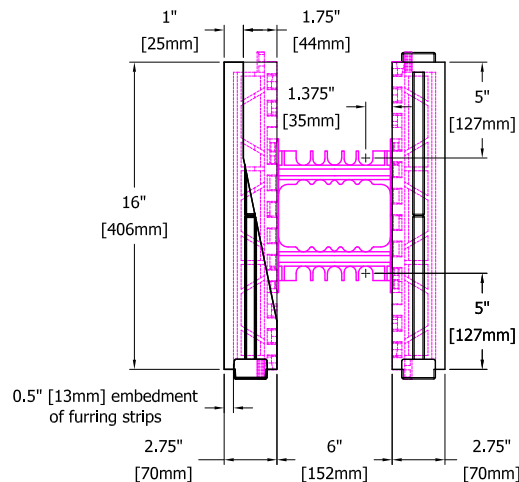

END VIEW

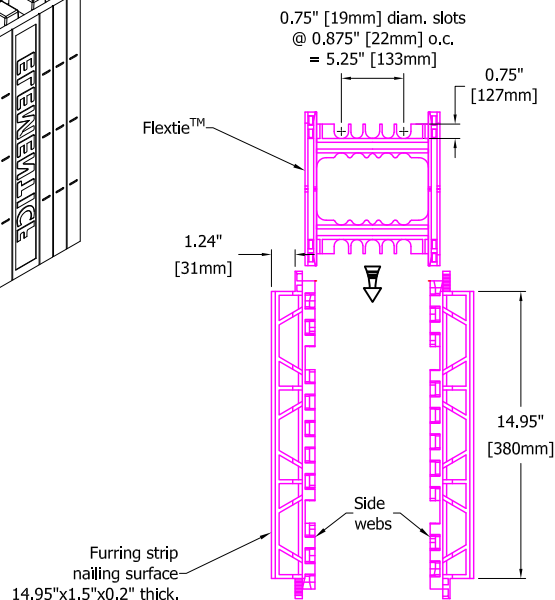
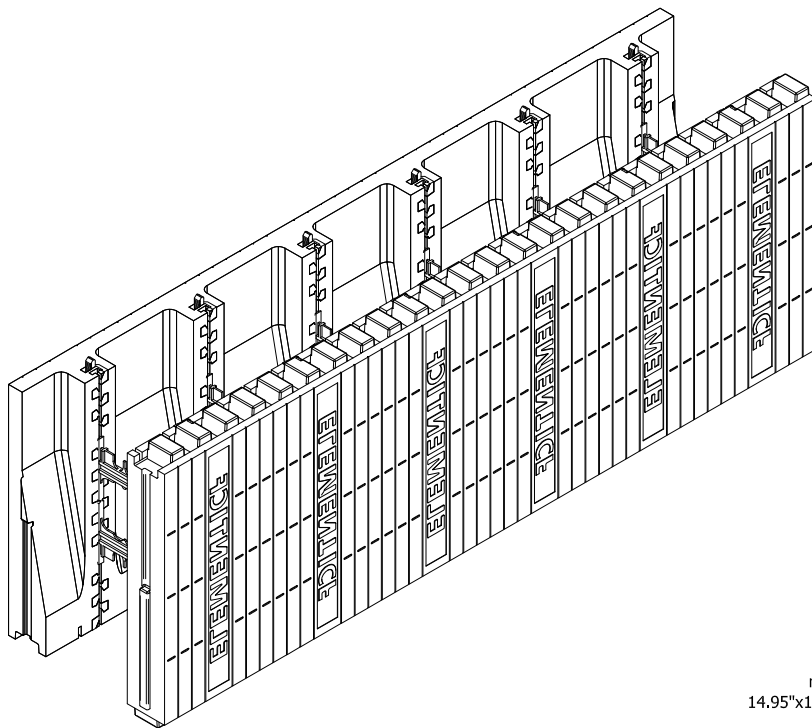

WEB TIE COMPONENTS

TAPER TOP BLOCK SPECS

Conc. Vol. (y3)	0.111
Conc. Vol. (ft3)	2.99
Conc. Vol. (m3)	0.085
Wall Area (sf)	5.333
R-value*	19.3
RSI*	3.39

*EPS form panels only



The drawing represented herein is to be used as a reference guide only; the user shall check to ensure the drawing meets local building codes and construction practices by consulting local building officials and professionals, including any additional requirements. Logix Brands reserves the right to make changes to the drawing without notice and assumes no liability in connection with the use of the drawing including modification, copying or distribution.

Drawing:
5.1.2

Date:
Dec 13/22

Pg:
1/1

Title:
SITE-ASSEMBLED TAPER TOP BLOCK (6 INCH)