

**ELEVATION
INTERIOR FACE**

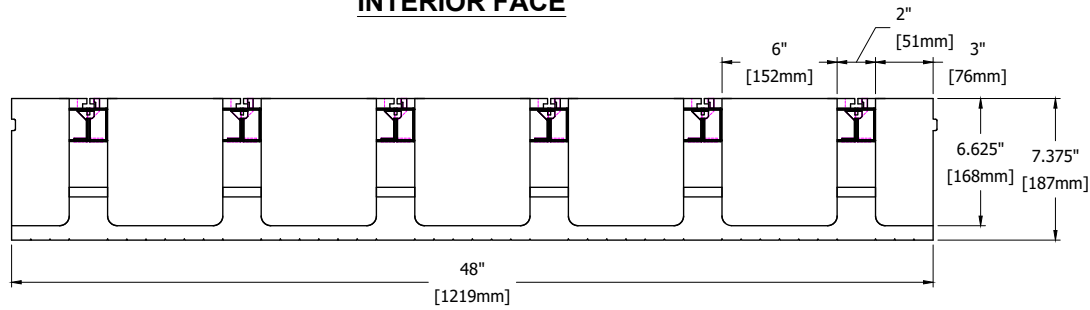

PLAN VIEW

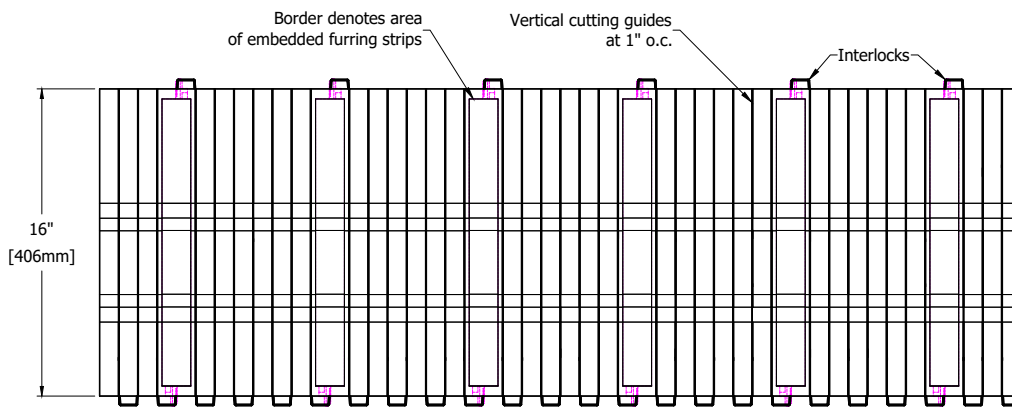

**ELEVATION
EXTERIOR FACE**

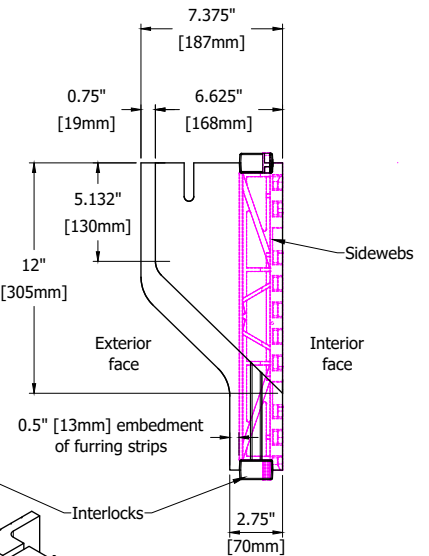

END VIEW

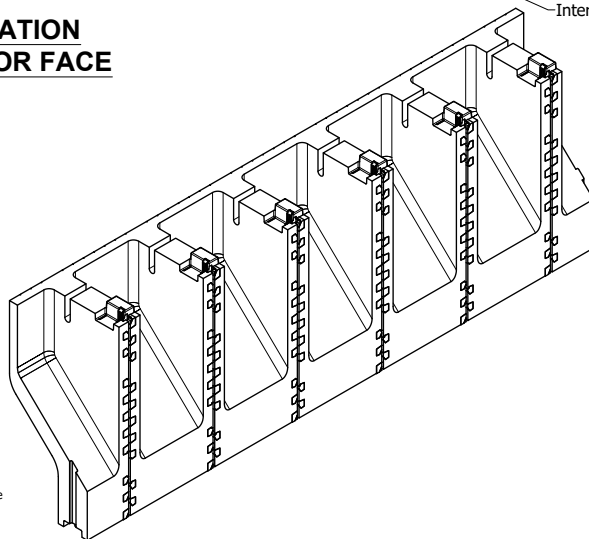

NOTE:

Use of the Element ICF Brick Ledge requires steel stirrups to transfer loads safely into the wall structure. Failure to install the stirrup reinforcement will significantly reduce load capacity and may result in cracking, deformation, or structural failure of the ledge. Always install stirrups as shown in CAD Steel Reinforcing section to achieve rated performance.

Where a licensed professional engineer provides project-specific design details for the Element Brick Ledge, those details shall govern and supersede the requirements and warnings on this label. The builder remains responsible for implementing the engineer's design and providing all required support.

